



# R700S

## MOBILE TRACK-MOUNTED IMPACT CRUSHER

Performance up to 170 st/h / 150 t/h\*

Transport weight 43,900 lbs / 19,9 t

Fully hydraulic



PRODUCT DESCRIPTION  
EFFICIENT  
CRUSHING  
TECHNOLOGY



Rockster Austria International GmbH | Matzelsdorf 72, 4212 Neumarkt i.M., Austria  
Tel.: +43 720 70 1212 | office@rockster.at | www.rockster.at



**ROCKSTER**<sup>®</sup>

\* depending on material

COMPACT, FLEXIBLE PERFORMANCE

**R700S**



MOBILE TRACK-MOUNTED IMPACT CRUSHER

**R700S**



**HIGH & CONSTANT  
PERFORMANCE**



**INCREASED  
MOBILITY**



**EASE OF  
OPERATION**



**MAXIMUM  
FLEXIBILITY**



**HYDROSTATIC  
DRIVE**



**LONG-TERM  
RELIABILITY**



**CLIMATE  
FRIENDLY**

Rockster Austria International GmbH | Matzelsdorf 72, 4212 Neumarkt i.M., Austria  
Tel.: +43 720 70 1212 | office@rockster.at | www.rockster.at



**ROCKSTER®**



Perfect cubic final grain

## COMPACT. FLEXIBLE. POWERFUL.

The mobile impact crusher R700S is specially developed for applications where space is limited such as for inner-city projects. Because of its optimal dimensions, the R700S is easily transported from one jobsite to another. It is the perfect combination of compactness and maximum performance.

Rockster's mobile track-mounted impact crusher is based on a fully hydraulically concept, which allows flexible recycling of asphalt, concrete and demolition debris.

Besides previously mentioned materials, the R700S is also suitable for precise processing of natural stone.

### R700S IS THE MOST COMPACT SOLUTION FOR RECYCLING AND CRUSHING OF:

#### CONCRETE



Recycled concrete blocks 0/16

#### DEMOLITION DEBRIS



Subbase road 0/32

#### ASPHALT



Road 0/32

#### BRICK



Refilling pipelines 0/64

#### VIRGIN STONE



Forest road 0/32

# MAIN DIMENSIONS

**R700S**

## Transport dimensions

Length:	29'6" / 9,00 m
Width:	7'11" / 2,41 m
Height:	10'2" / 3,10 m
Height folded main belt:	10'4" / 3,15 m
Transport weight:	43.900 lbs / 19,9 t

## Feeding & discharge height

Feeding height:	10'2" / 3,10 m
Main discharge belt:	~ 9'10" / 3,00 m
Side discharge belt:	~ 7'3" / 2,20 m

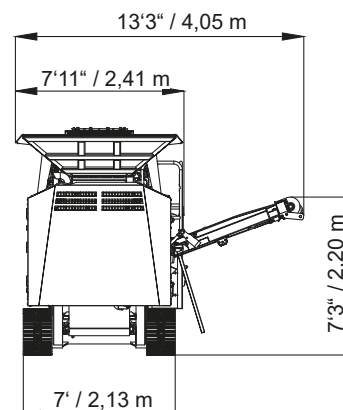
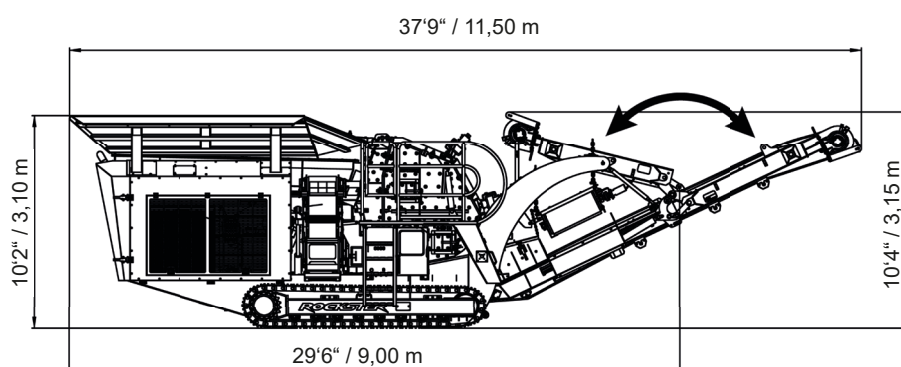

## TECHNICAL DETAILS

### MAXIMUM FLEXIBILITY

The Rockster impact crusher guarantees highest performance at a very high crushing ratio.

Due to two hydraulically adjustable swing-beams, as well as the rotor speed variation, the final grain can be optimally defined. High quality blow bars can be used bilaterally too and are chosen individually depending on the application.

The blow bar exchange is possible through the optional built-on blow bar exchange device, therefore an external lifting device is not necessary. High quality wear materials ensure reduced wear.

### Impact crusher

Inlet opening:	28" x 26" / 710 x 650 mm
Impact circle diameter:	37" / 930 mm
Rotor equipment:	4 blow bars
Crushing ration:	1:10 - 1:50
Performance:	up to 170 st/h / 150 t/h
Rotor speed (continuously adjustable):	up to 850 rpm
Weight:	ca. 13,150 lbs / 5.950 kg
Drive:	hydrostatic
Gap adjustment (adjusted on display):	fully hydraulic
Dust suppression:	At the crusher inlet & outlet



## Drive

Engine (electronically regulated):	Volvo Tier 3a / Stage IIIA - 160 kW / ~220 HP
	Volvo Tier 4 Final / Stage IV - 160 kW / ~220 HP
	Volvo Stage V - 160 kW / ~220 HP
Cylinder:	6
Cooling system:	water

The drive system is located at the rear of the machine, enclosed in a sound-proofed housing. Engine openings are positioned on all sides for easy access, service and overall maintenance.

The hydraulic pump for all auxiliary drives (main discharge belt, side discharge belt, vibration chute, crawler gear...) as well as the pump for the hydrostat are driven via a distributing gear unit which is flange-mounted on the drive engine. The hydrostat activates the crusher via a V-belt drive.



### ADVANTAGES OF THE HYDROSTATIC DRIVE

- > Elimination of conventional clutch. No wear.
- > Individual adjustment of crusher speed
- > Crusher overload protection
- > Power adjustment according to individual requirements
- > Uniform throughput
- > Enormous power reserves

## Feed hopper

Material:	Hardox 400
Volume:	4.2 yd <sup>3</sup> / 3,2 m <sup>3</sup>
Length:	11' / 3350 mm
Width:	6'11" / 2100 mm
Height:	10'2" / 3100 mm

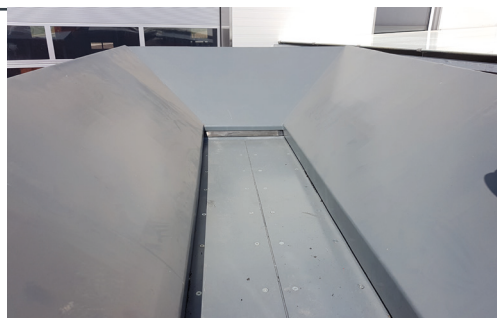

## Vibration chute with pre-screening

Material:	Hardox 450
Length:	43" / 1100 mm
Width:	36" / 900 mm
Type:	Zig zag
Option:	bar screen
Drive:	hydraulic - continuously adjustable



## Bypass

The switchable chute (Bypass) enables the discharge of pre-screened material on the side or onto the main discharge belt.

Easy switch via hand lever.

**No special assembly necessary.**

**No wear. No service.**



## Main discharge belt

Belt width:	32" / 800 mm
Discharge height:	~ 9'10" / 3,00 m
Angle:	25,5°
Drive:	hydraulic, continuously variable

The main discharge belt is hydraulically foldable for transport purposes.



## Side discharge belt

Belt width:	16" / 400 mm
Discharge height:	~ 7'3" / 2,20 m
Angle:	21°
Drive:	hydraulic

The side discharge belt is hydraulically foldable for transport purposes.



## Magnetic separator

Type:	Permanent magnet
Belt width:	30" / 750 mm
Weight:	1940 lbs / 880 kg
Drive:	hydraulic



## Caterpillar crawler

Tread width:	16" / 400 mm - slanted
Wheel base:	9'6" / 2900 mm
Surface:	triple ribbed pads
Drive:	2-speed hydraulic



## Control panel

Central control/operating unit ensures an easy operation and machine monitoring in connection with a wireless remote control.

**Fully automatic engine Start-Stop system with only one button.**

- > Save the operation settings for various applications
- > Error monitoring - error log
- > Input & output status
- > Fast start of operation (QUICKSTART-Function)



# FEATURES

# R700S

## Environmentally friendly

Reduction of emissions through:

- > efficient dust suppression
- > sound-proofed housing
- > motor drive according to the latest technology standards



## Easy maintenance & ideal accessibility

Large covers enable optimal accessibility when it comes to service and maintenance. Furthermore they ensure optimal ventilation of the drive-unit and the cooler.

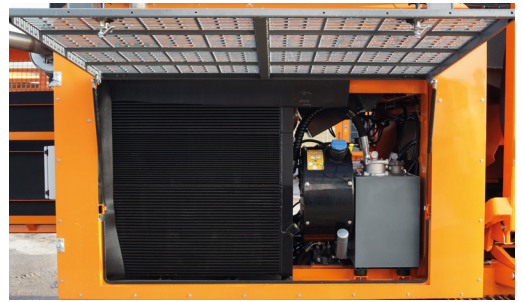

# OPTIONS



Water pump



Blow-bar exchange system



Main belt - wear protection



Air compressor



Sound protection cover



Belt scale  
incl. printer

# OPTION - DUST COVER



KEEPING AIR POLLUTION TO A MINIMUM





# OPTION: SCREENING SYSTEM - SCREEN BOX RS73 + DOUBLE-FUNCTIONAL RETURN- OR STOCKPILE BELT RB65

**R700S**

## Defined final product in one workflow

The optional screening system consists of the compact circular vibrating screen RS73 in combination with the return belt RB65. The screening system is a perfect addition for the production of 100 % defined final grain.

The components are mounted directly onto the main discharge belt and are driven through the additional hydraulic system of the crusher.

In addition, the return belt can be used as a stockpile belt, which enables the production of the second product.



## Vibrating screen

Screen size:	6' x 3'3" / 1830 x 1000 mm
Standard mesh:	1 1/2" / 38 mm

Special screens available on demand



## Discharge conveyor - fines

Belt width:	32" / 800 mm
Discharge height:	~ 9'6" / 2,90 m

## Discharge conveyor - oversize grain

Belt width:	16" / 400 mm
-------------	--------------



## RB65 return or stockpile belt

Belt width:	16" / 400 mm
Discharge height:	~ 11'2" / 3,4 m



## Transport dimensions R700S + RS73 + RB65

Length:	46'3" / 14,10 m	Width:	8'3" / 2,52 m
Height:	10'2" / 3,10 m	Weight:	50,300 lbs / 22,80 t

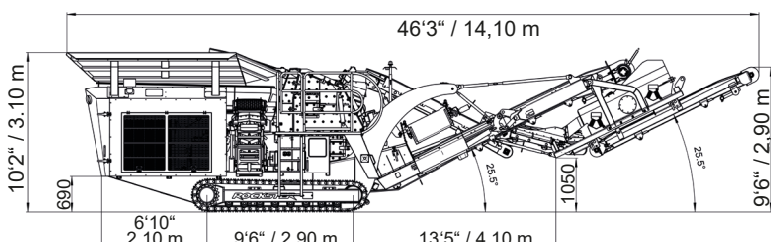

# WORKING DIMENSIONS

# R700S

## R700S

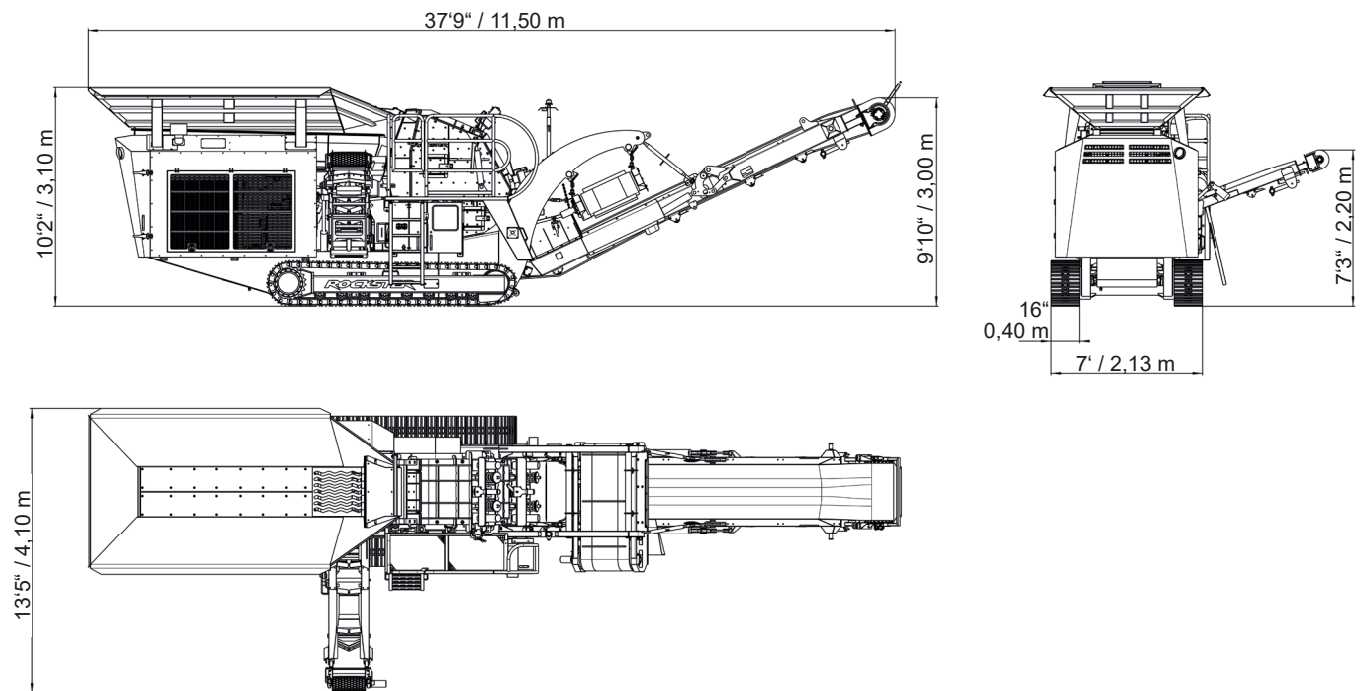

## R700S with screening system

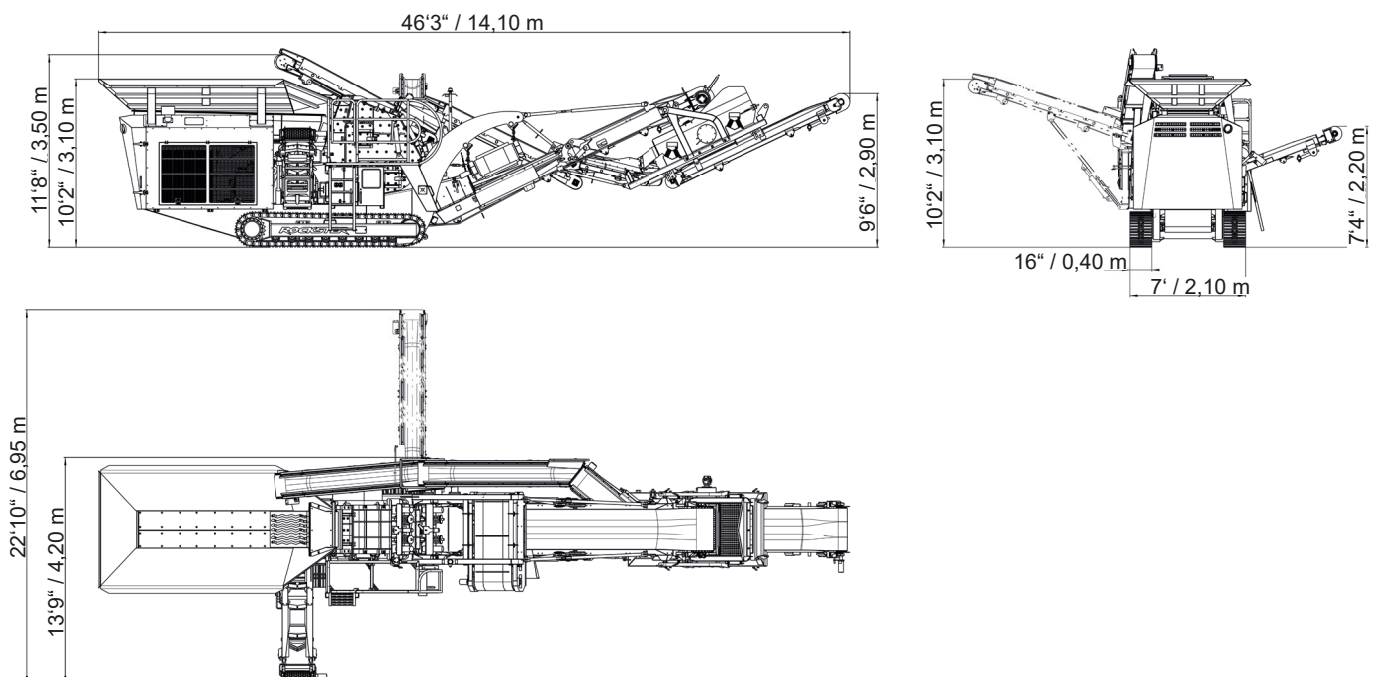

# CUSTOMER FEEDBACK

# R700S



*"We are so flexible in terms of processing different aggregates and the material we produce with our crusher is of high value. We do also like the fact that the return belt can be turned aside, and we can make another fraction, as well as the fine side belt that can be pulled off. The screen box is also very beneficial as it allows us to produce different material sizes by just switching some screens. "*

**Arist de Wolff, CEO**  
Alakona Corp, Hawaii, USA



*"At 2,800 m, the Rockster crusher did a very good job in producing optimum final product 0/22mm using a closed circuit crusher with a screen box and return belt."*

**Richard Grüner GmbH, Austria**



SCAN & WATCH



*"I was made aware of ROCKSTER's mobile crushers by other companies. For me it is important that the plant is easy to transport and still very powerful. Since our jobs often need to be done in a confined spaces and especially in road construction in steep terrain, the crusher must not be too big and heavy."*

**Christoph Wagner, Founder and CEO**  
Wagner Erdbau, Austria



SCAN & READ

# GENERAL INFORMATION



<b>HIGH &amp; CONSTANT PERFORMANCE</b>	<b>INCREASED MOBILITY</b>	<b>EASE OF OPERATION</b>	<b>MAXIMUM FLEXIBILITY</b>	<b>HYDROSTATIC DRIVE</b>	<b>LONG-TERM RELIABILITY</b>	<b>CLIMATE FRIENDLY</b>

Austrian based manufacturer Rockster Austria International GmbH has a longlasting reputation and the know-how in demolition and screening industry.

The product line includes, among others, track mounted impact and jaw crushers, screening machinery and tracked stackers. "Our mobile crushers and screeners are used for profitable & economical recycling and processing of asphalt, concrete and construction waste, as well as for natural stone.

With innovations like The Original DUPLEX system or double-functional return belt, we repeatedly demonstrate our progressive approach towards improving and developing more efficient recycling & processing methods."

Rockster machines are sold in more than 50 countries worldwide. Our sales partner network guarantees the ideal on-site package of product and service in order to support and secure the daily success of our customers.



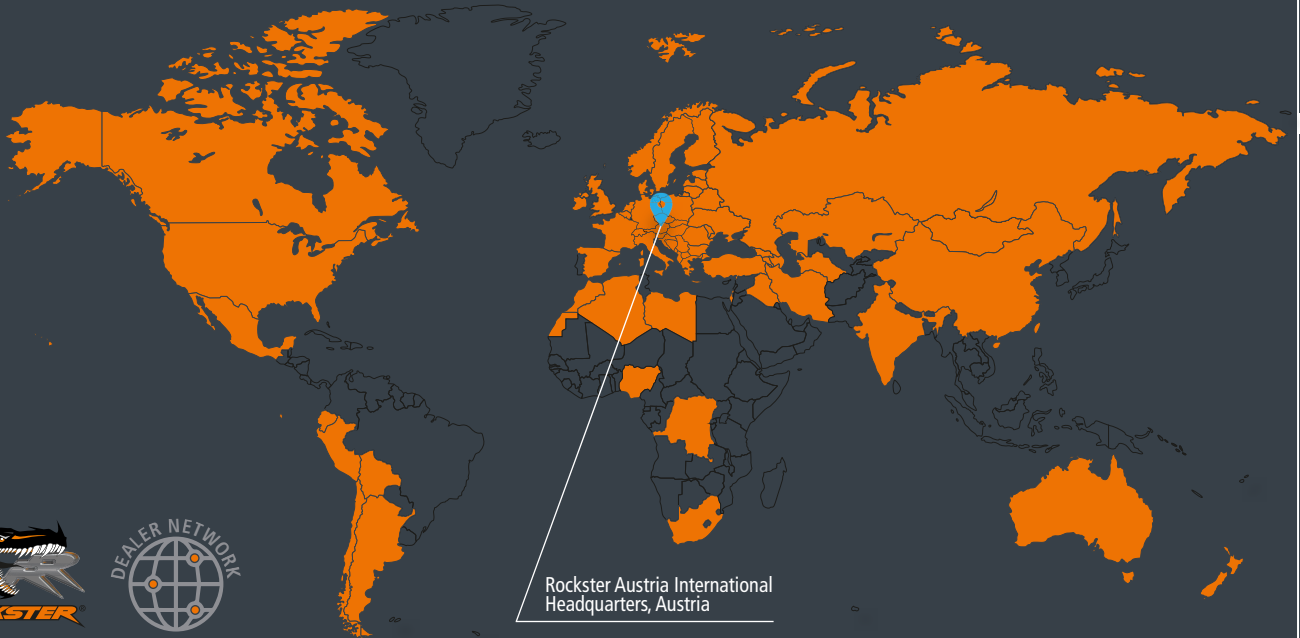

Rockster Austria International  
Headquarters, Austria

**SOLD IN MORE THAN 50 COUNTRIES WORLDWIDE**

**EFFICIENT  
CRUSHING TECHNOLOGIE**

Rockster Austria International GmbH | Matzelsdorf 72, 4212 Neumarkt i.M., Austria  
Tel.: +43 720 70 1212 | office@rockster.at | www.rockster.at

