



R800

MOBILE TRACK-MOUNTED JAW CRUSHER

Performance up to 140 st/h / 120 t/h*

Transport weight 56,700 lbs / 25,7 t

Fully hydraulic



PRODUCT DESCRIPTION

EFFICIENT
CRUSHING
TECHNOLOGY



Rockster Austria International GmbH | Matzelsdorf 72, 4212 Neumarkt i.M., Austria
Tel.: +43 720 70 1212 | office@rockster.at | www.rockster.at



ROCKSTER[®]

* depending on material

PRODUCT DESCRIPTION

R800



MOBILE TRACK-MOUNTED JAW CRUSHER

R800



**HIGH & CONSTANT
PERFORMANCE**



**INCREASED
MOBILITY**



**EASE OF
OPERATION**



**MAXIMUM
FLEXIBILITY**



**HYDROSTATIC
DRIVE**



**LONG-TERM
RELIABILITY**



**CLIMATE
FRIENDLY**

Rockster Austria International GmbH | Matzelsdorf 72, 4212 Neumarkt i.M., Austria
Tel.: +43 720 70 1212 | office@rockster.at | www.rockster.at



ROCKSTER®



Perfect final grain

COMPACT. FLEXIBLE. POWERFUL.

Rising landfill costs and raw material prices, as well as the need for waste separation, makes the recycling of construction materials very pertinent. This not only protects the environment, but also helps building contractors to save costs.

Rockster mobile crushers guarantee profitable recycling of concrete, demolition debris and especially

for processing hard natural stone. The compact mobile track-mounted impact crusher R800 offers best mobility and high ease of use because of numerous technological refinements. Versatile setting options ensure excellent final grain quality and increased usability.

R800 IS THE MOST COMPACT SOLUTION FOR RECYCLING AND CRUSHING OF:

CONCRETE



Recycled concrete blocks 0/16

DEMOLITION DEBRIS



Subbase road 0/32

BRICK



Refilling pipelines 0/64

VIRGIN STONE



Subbase road 0/32

MAIN DIMENSIONS

R800

Transport dimensions

Length:	31'6" / 9,60 m
Width:	8'3" / 2,50 m
Height:	10'6" / 3,20 m
Transport weight:	56.700 lbs / 25,7 t

Feeding & discharge height

Feeding height:	10'6" / 3,20 m
Main discharge belt:	~ 10'6" / 3,20 m
Side discharge belt:	~ 7'7" / 2,30 m

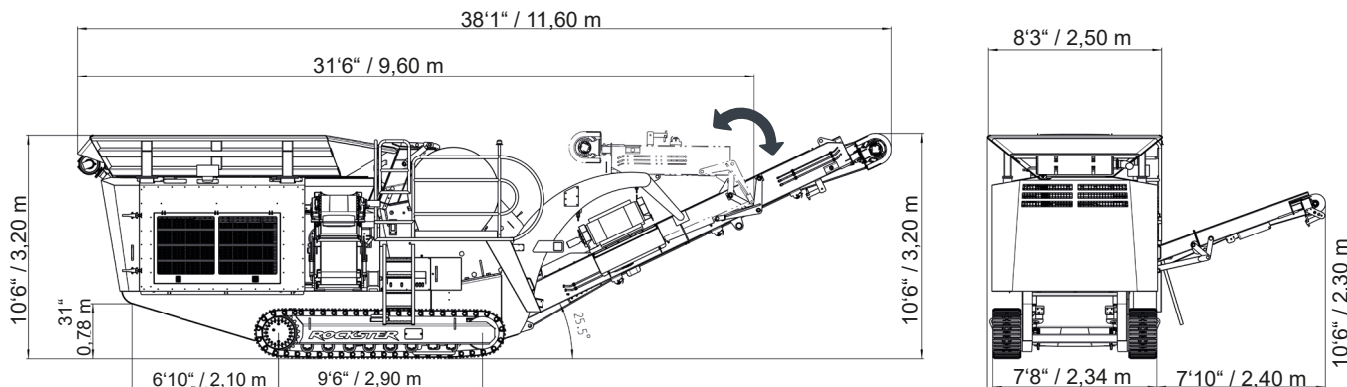

TECHNICAL DETAILS

The fully hydraulic Jaw crusher R800 is driven through a powerful, electronically controlled VOLVO engine. The crusher itself is driven via a hydrostatic motor and the gap adjustment is hydraulically regulated. The crushed material falls into an adjustable bypass-chute that allows the discharge to the main or side conveyor belt.

The hydraulically adjustable Rockster jaw crusher is the ideal solution for all operations that require highest demands on the wear parts.

Even under toughest conditions, the R800 guarantees highest crushing power and lowest wear.

Jaw crusher

Inlet opening:	32" x 20" / 800 x 500 mm
Crushing ratio:	1:8
Performance:	up to 120 t/h / 140 st/h
Rotor speed (continuously adjustable):	up to 320 min ⁻¹
Weight:	17,600 lbs / 8.000 kg
Drive:	hydrostatic
Gap adjustment (adjusted on display):	fully hydraulic
Crusher outlet:	420 mm



Drive

Engine (electronically regulated):	Volvo Tier 3A / Stage IIIA - 200 kW / ~268 HP
	Volvo Tier 4 Final / Stage IV - 210 kW / ~282 HP
	Volvo STAGE V - 210 kW / ~282 HP
Cylinder:	6
Cooling system:	water

The drive system is located at the rear of the machine, enclosed in a sound-proofed housing. Engine openings are positioned on all sides for easy access, service and overall maintenance.

The hydraulic pump for all auxiliary drives (main discharge belt, side discharge belt, vibration chute, crawler gear...) as well as the pump for the hydrostat are driven via a distributing gear unit which is flange-mounted on the drive engine. The hydrostat activates the crusher via a V-belt drive.



ADVANTAGES OF THE HYDROSTATIC DRIVE

- > Elimination of conventional clutch. No wear.
- > Individual adjustment of crusher speed
- > Crusher overload protection
- > Power adjustment according to individual requirements
- > Uniform throughput
- > Enormous power reserves
- > Adjustment of rotating direction (Duplex)

Feed hopper

Material:	Hardox 400
Volume:	5.3 yd ³ / 4,0 m ³
Length:	12'6" / 3800 mm
Width:	8'2" / 2500 mm
Height:	10'6" / 3200 mm



Vibration chute with pre-screening

Material:	Hardox 450
Length:	47" / 1200 mm
Width:	36" / 900 mm
Type:	Zig zag
Option:	bar screen
Drive:	hydraulic - continuously adjustable



Bypass

The switchable chute (Bypass) enables the discharge of pre-screened material on the side or onto the main discharge belt.

Easy switch via hand lever.

No special assembly necessary.
No wear. No service.



Main discharge belt

Belt width:	40" / 1000 mm
Discharge height:	~ 10'6" / 3,20 m
Angle:	26°
Drive:	hydraulic, continuously variable

The main discharge belt is hydraulically foldable for transport purposes.



Side discharge belt

Belt width:	20" / 500 mm
Discharge height:	~ 7'6" / 2,30 m
Angle:	20°
Drive:	hydraulic

The side discharge belt is hydraulically foldable for transport purposes.



Magnetic separator

Type:	Permanent magnet
Belt width:	30" / 750 mm
Weight:	2645 lbs / 1200 kg
Drive:	hydraulic



Caterpillar crawler

Tread width:	16" / 400 mm - slanted
Wheel base:	9'6" / 2.90 m
Surface:	triple ribbed pads
Drive:	2-speed hydraulic



Control panel

Central control/operating unit ensures an easy operation and machine monitoring in connection with a wireless remote control.

Fully automatic engine Start-Stop system with only one button.

- > Save the operation settings for various applications
- > Error monitoring - error log
- > Input & output status
- > Fast start of operation (QUICKSTART-Function)



FEATURES

R800

Environmentally friendly

Reduction of emissions through:

- > efficient dust suppression
- > sound-proofed housing
- > motor drive according to the latest technology standards



Easy maintenance & ideal accessibility

Large covers enable optimal accessibility when it comes to service and maintenance. Furthermore they ensure optimal ventilation of the drive-unit and the cooler.

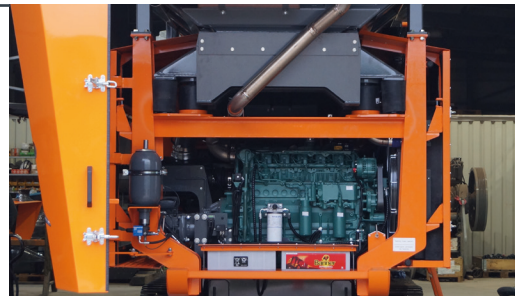
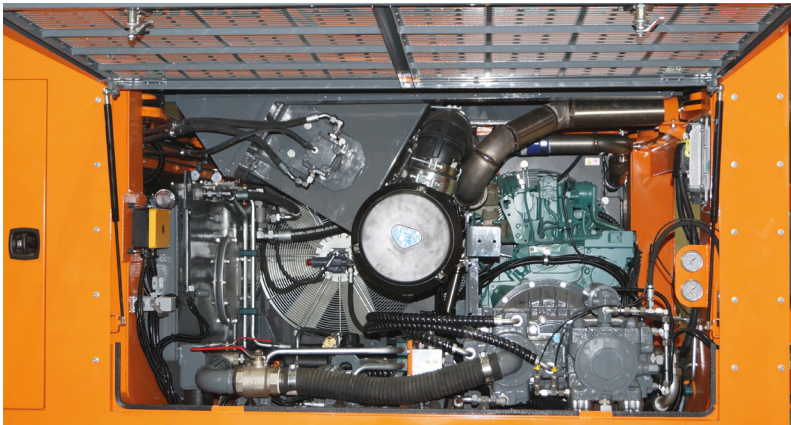

OPTIONS

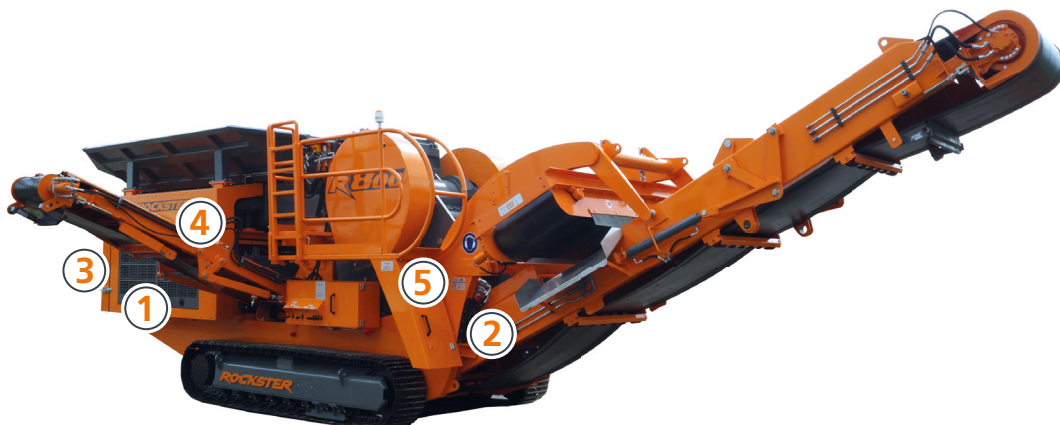

Water pump



Main belt - wear protection



Air compressor



Sound protection cover



Belt scale
incl. printer

OPTIONS

R800

DUPLEX SYSTEM

The unique design of the ROCKSTER crusher allows the transformation from a jaw crusher to an impact crusher and vice versa in only a few hours. Achieve maximum machine utilization by using one carrier and different crusher units to rapidly adapt to different job requirements.



R900
Impact crusher

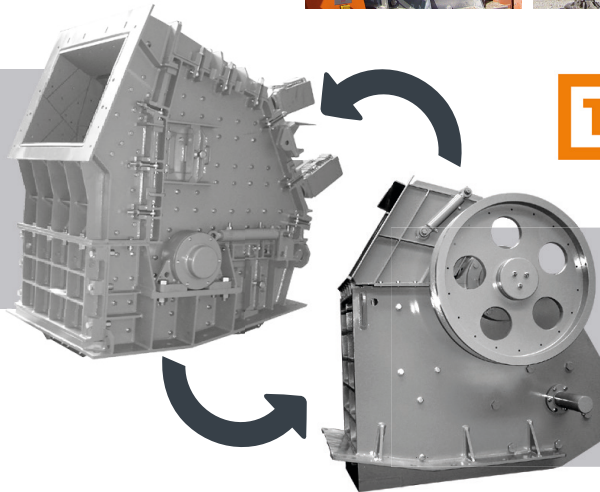

THE ORIGINAL
since 2004

R800
Jaw crusher

AIR BLOWER - for cleaner and higher quality final product

RVB1700

The Rockster Air blower RVB1700 is used to efficiently separate non-aggregates from the final end-material, which results in a cleaner and higher quality final product. This enables Rockster customers to work more environmentally friendly and economically.



Technical details

Air volume:	up to 1.700 m ³ /h / 2,223 yd ³ /h
Differential pressure:	up to 7.000 Pa
Drive power:	up to approx. 15 kW / 20 hp
Drive - rpm:	up to 3.200 min ⁻¹
Weight:	approx. 150 kg / 330 lbs

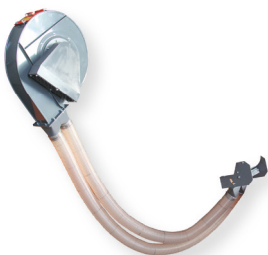

VIDEO



OPTION: SCREENING SYSTEM SCREEN BOX RS83 + RETURN BELT RB75

R800

Defined final product in one workflow

The optional screening system consists of the compact circular vibrating screen RS83 in combination with the return belt RB75. The screening system is a perfect addition for the production of 100 % defined final grain.

The components are mounted directly onto the main discharge belt and are driven through the additional hydraulic system of the crusher.



Vibrating screen

Screen size:	6' x 4' / 1830 x 1200 mm
Standard mesh:	1 1/2" / 38 mm

Special screens available on demand



Discharge conveyor - fines

Belt width:	32" / 800 mm
Discharge height:	~ 10'5" / 3,20 m



Discharge conveyor - oversize grain

Belt width:	20" / 500 mm
-------------	--------------



RB75 return belt

Belt width:	16" / 400 mm
-------------	--------------



Transport dimensions R800 + RS83 + RB75

Length:	46'7" / 14,20 m	Width:	8'3" / 2,50 m
Height:	10'8" / 3,25 m	Weight:	64,200 lbs / 29,10 t

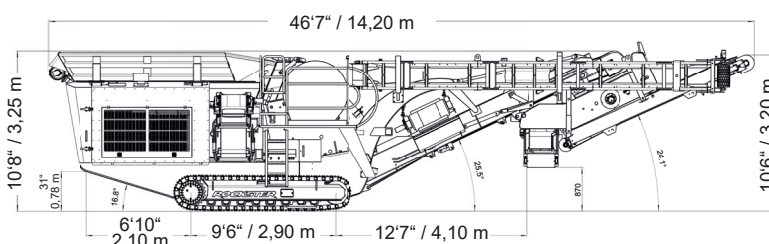

WORKING DIMENSIONS

R800

R800

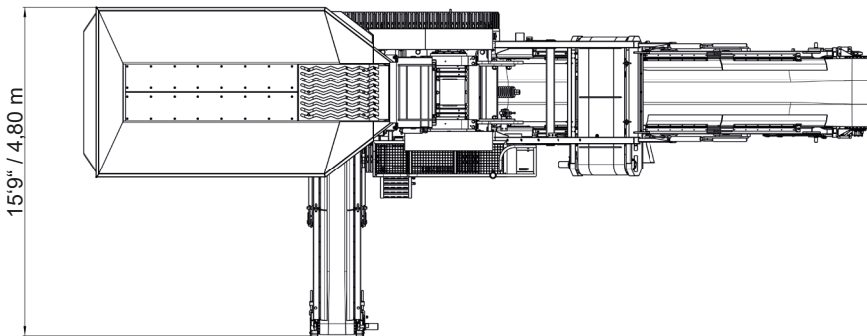
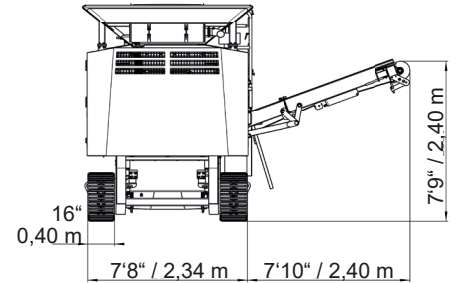
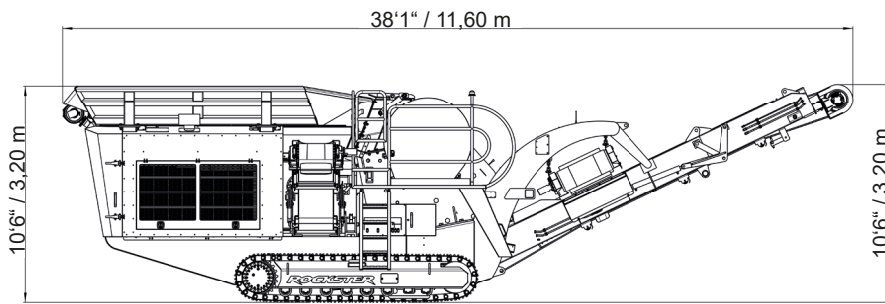

R800 with screening system

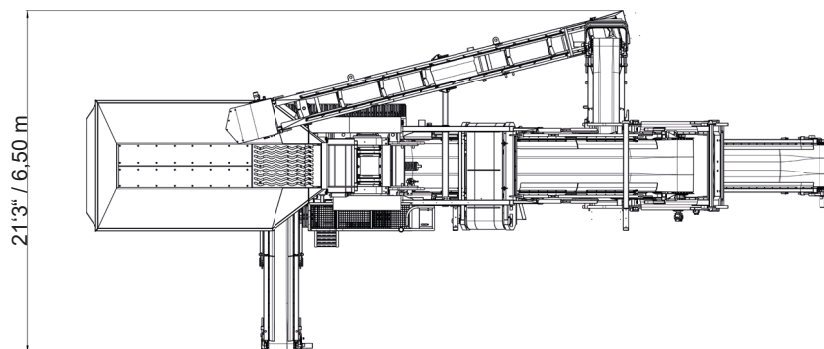
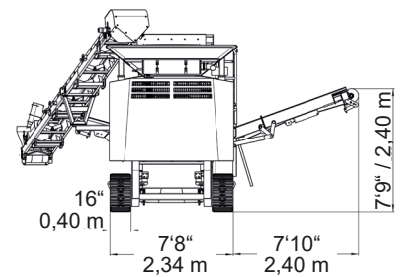
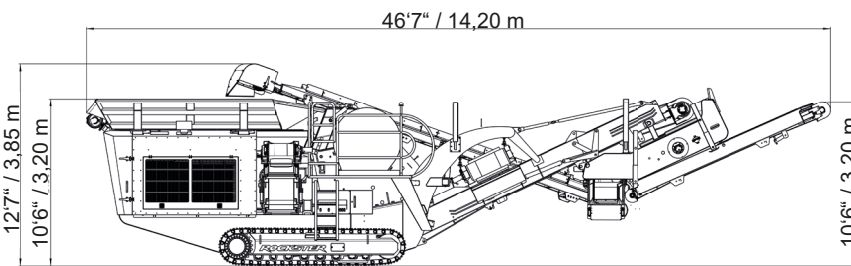



SCAN & WATCH

„With the flexibility of Rockster R800 , we can now process the material on site and immediately use the final product for road building. We produce a lot of material for sub-base, which shouldn't have too many fines. We really like the efficiency and material production of the jaw crusher, the end grain quality is optimal for our areas of application.“

**Peter Happenhofer, Founder and CEO
Happenhofer Bau, Austria**



„The advantages of this crusher are compact transport dimensions and low weight that do not have special restrictions for transportation.“

**Maksim Perminov, Rockster partner in Russia
Kombinat, Russia**



SCAN & WATCH



„In addition to the challenging recycling of demolition debris the R800 jaw crusher is ideally suited for applications in hard natural stone. Since R800 doesn't need a special permit for transport, it can be moved in no time from one site to another.“

Auto-Bau, Poland



SCAN & READ

GENERAL INFORMATION



**HIGH & CONSTANT
PERFORMANCE**



**INCREASED
MOBILITY**



**EASE OF
OPERATION**



**MAXIMUM
FLEXIBILITY**



**HYDROSTATIC
DRIVE**



**LONG-TERM
RELIABILITY**



**CLIMATE
FRIENDLY**

Austrian based manufacturer Rockster Austria International GmbH has a longlasting reputation and the know-how in demolition and screening industry.

The product line includes, among others, track mounted impact and jaw crushers, screening machinery and tracked stackers. "Our mobile crushers and screeners are used for profitable & economical recycling and processing of asphalt, concrete and construction waste, as well as for natural stone.

With innovations like The Original DUPLEX system or double-functional return belt, we repeatedly demonstrate our progressive approach towards improving and developing more efficient recycling & processing methods."

Rockster machines are sold in more than 50 countries worldwide. Our sales partner network guarantees the ideal on-site package of product and service in order to support and secure the daily success of our customers.



Rockster Austria International GmbH | Matzelsdorf 72, 4212 Neumarkt i.M., Austria
Tel.: +43 720 70 1212 | office@rockster.at | www.rockster.at



ROCKSTER®

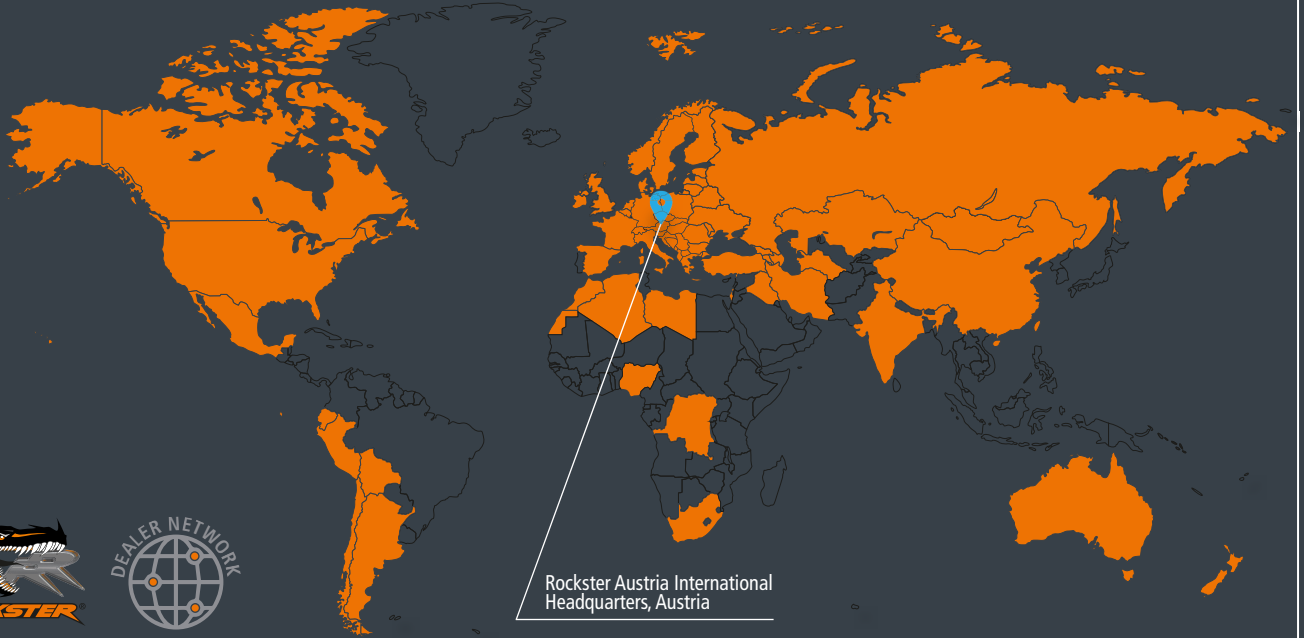

Rockster Austria International
Headquarters, Austria

SOLD IN MORE THAN 50 COUNTRIES WORLDWIDE

**EFFICIENT
CRUSHING TECHNOLOGIE**

Rockster Austria International GmbH | Matzelsdorf 72, 4212 Neumarkt i.M., Austria
Tel.: +43 720 70 1212 | office@rockster.at | www.rockster.at

