



RDS 410

MOBILE TRACK-MOUNTED FINISHING SCREEN

Feed hopper 7.6 yd³ / 5,8 m³

Screen surface 10' x 4' / 3,0 x 1,2 m

Transport weight ~ 34,200 lbs / 15,5 t

EFFICIENT
SCREENING
TECHNOLOGY

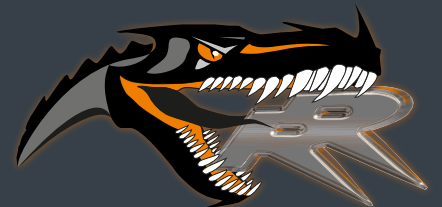

Rockster Austria International GmbH | Matzelsdorf 72, 4212 Neumarkt i.M., Austria
Tel.: +43 720 70 1212 | office@rockster.at | www.rockster.at



ROCKSTER[®]

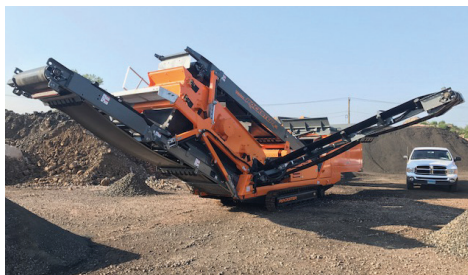

MOBILE TRACK-MOUNTED FINISHING SCREEN

RDS410

2-DECK

**POWERFUL
EFFICIENT
SEPARATION**



3 precisely defined fractions

POWERFUL SEPARATION WITH COMPACT FINISHING SCREEN

The extremely efficient, but still very compact track-mounted finishing screen RDS410 is the right choice for screening sand, gravel, construction waste, coal, wood chips as well as recycling materials. The high efficiency makes the screening of finest grain

more productive and profitable. The RDS410 ensures the optimum in flexibility and mobility with the greatest possible performance coupled with maximum fuel efficiency.

FEATURES & BENEFITS

- > Short set-up time
- > Easy handling
- > Low feeding height
- > Robust steel construction
- > Optimal transport dimensions
- > High energy screenbox
- > Hydraulic folding discharge belts
- > Fully adjustable spreader plate for optimum screening
- > Screenbox and fines belt lowers hydraulically to allow mesh change

Applications

- > Produces 3 final fractions as an individual machine
- > Final screening unit after the crusher to separate the crushed product in 3 final fractions

PERFORMANCE	
Max. feed size:	3" / 75 mm
Capacity:	up to 220 st/h / 200t/h

HOPPER	
Width:	4'5" / 1,38 m
Length:	9'1" / 2,80
Max. Volume:	7.1 yd ³ / 5,8 m ³

TIPPING GRID	
Width:	7'0" / 2,15 m
Length:	11'9" / 3,65
Tip function:	Radio remote or manual

SCREEN SURFACE (both decks)	
Top deck:	10' x 4' / 3 x 1,2 m
Bottom deck:	10' x 4' / 3 x 1,2 m
Angle:	28-36°

FEEDER BELT	
Width:	32" / 800 mm
Type:	Plain belt
Control:	Variable speed

MAIN BELT	
Width:	32" / 800 mm
Control:	Variable speed

FINES (TAIL) BELT	
Width:	42" / 1050 mm
Discharge Height:	~ 9'4" / 2,85 m
Control:	Variable speed

MIDS BELT	
Width:	26" / 650 mm
Discharge Height:	9'10" / 3,00 m
Control:	Variable speed

OVERSIZE BELT	
Width:	26" / 650 mm
Discharge Height:	9'10" / 3,00 m
Control:	Variable speed

TRACKS	
Width:	12" / 300 mm
Speed:	0,6 miles/h - 1 km/h

DRIVE UNIT	
Tier 3A	JCB444 DieselMax - 86 HP / 63kW T.Deutz 2011 - 49
Tier 4 Final	JCB EcoMax - 78HP / 55kW
Diesel Tank:	49 US gallon / 185L
Hydraulic tank:	79 US gallon / 300L

OPTIONS

- > Stage V - T.Deutz 2.9 L4 - 68HP / 50kW
- > Screen decks: mesh or piano wire
- > Radio remote control



DIMENSIONS

RDS410

Working dimensions

Length:	44'6" / 13,60 m
Width:	36'1" / 11,0 m
Height:	14'1" / 4,30 m

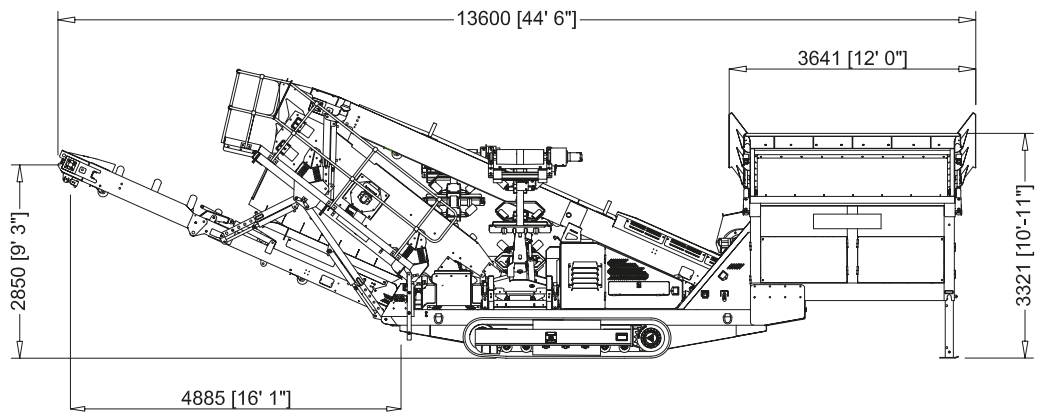
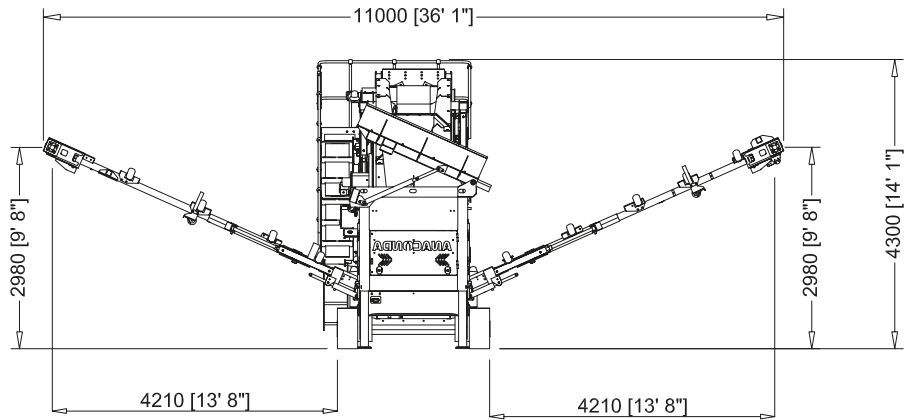

Transport dimensions

Length:	38'9" / 11,80 m
Width:	8'7" / 2,60 m
Height:	8'5" / 2,56 m
Weight:	34,000 lbs / 15,50 t

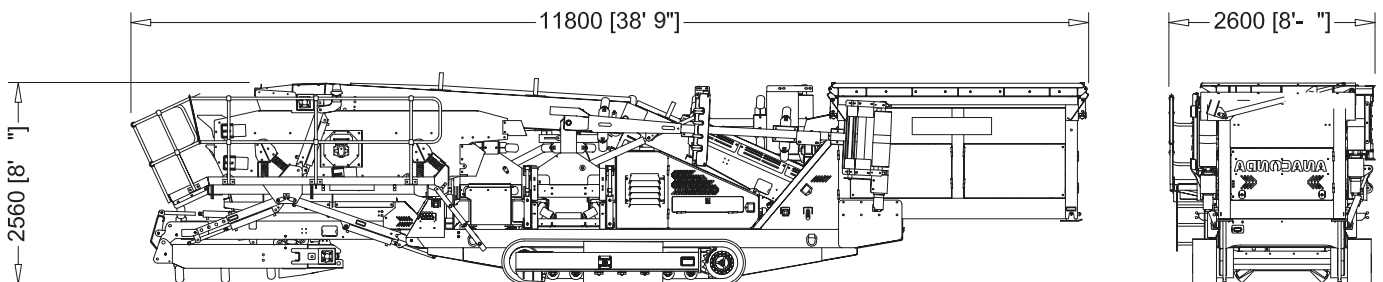

GENERAL INFORMATION



HIGH & CONSTANT PERFORMANCE	INCREASED MOBILITY	EASE OF OPERATION	MAXIMUM FLEXIBILITY	HYDROSTATIC DRIVE	LONG-TERM RELIABILITY	CLIMATE FRIENDLY

Austrian based manufacturer Rockster Austria International GmbH has a longlasting reputation and the know-how in demolition and screening industry.

The product line includes, among others, track mounted impact and jaw crushers, screening machinery and tracked stackers. "Our mobile crushers and screeners are used for profitable & economical recycling and processing of asphalt, concrete and construction waste, as well as for natural stone.

With innovations like The Original DUPLEX system or double-functional return belt, we repeatedly demonstrate our progressive approach towards improving and developing more efficient recycling & processing methods."

Rockster machines are sold in more than 50 countries worldwide. Our sales partner network guarantees the ideal on-site package of product and service in order to support and secure the daily success of our customers.



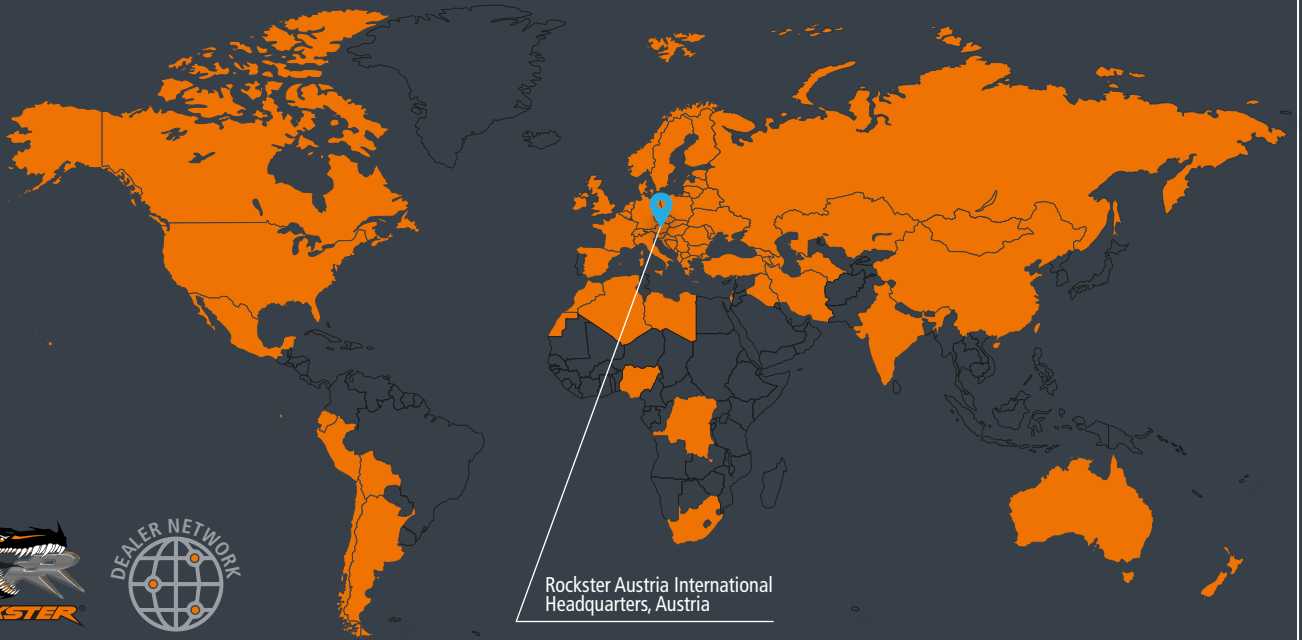

Rockster Austria International
Headquarters, Austria

SOLD IN MORE THAN 50 COUNTRIES WORLDWIDE

**EFFICIENT
SCREENING TECHNOLOGIE**

Rockster Austria International GmbH | Matzelsdorf 72, 4212 Neumarkt i.M., Austria
Tel.: +43 720 70 1212 | office@rockster.at | www.rockster.at

