



RSS514

MOBILE TRACK-MOUNTED SCALPING SCREEN

Feed hopper 9.4 yd³ / 7,2 m³

Screen surface 14'1" x 5' / 4,3 x 1,5 m

Transport weight ~ 53,600 lbs / 24,3 t

EFFICIENT
SCREENING
TECHNOLOGY

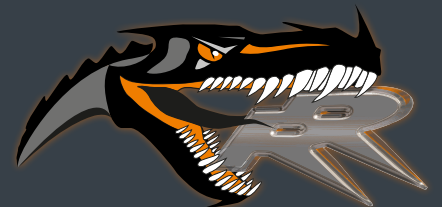

Rockster Austria International GmbH | Matzelsdorf 72, 4212 Neumarkt i.M., Austria
Tel.: +43 720 70 1212 | office@rockster.at | www.rockster.at



ROCKSTER[®]



MOBILE TRACK-MOUNTED SCALPING SCREEN

RSS514

**HIGHLY VERSATILE
MAXIMUM
THROUGHPUT**



3 final fractions

DESIGNED FOR A VARIETY OF APPLICATIONS & HIGHEST PERFORMANCE

RSS514 separates demolition debris, asphalt, concrete, bricks, coal, metal, top soil, compost and virgin stone. Also available either with a belt feeder or an optional steel apron feeder.

FEATURES & BENEFITS

- › Short set-up time
- › Easy handling
- › Low feeding height
- › Robust steel construction
- › Folding hopper tailgate for direct crusher feeding
- › Optimal transport dimensions
- › Hydraulically foldable hopper sides
- › Hydraulically foldable discharge belts
- › Easy access to the engine compartment
- › Screenbox walkways
- › Hydraulically raise the screenbox to facilitate mesh change

Applications

- › Produces 3 final fractions as an individual machine
- › Pre-screen before the crusher for production of 2 additional defined fractions, the separation of fines serves as wear protection & increases the crusher performance
- › Final screening unit after the crusher to separate the crushed product into 3 final fractions

TECHNICAL DETAILS

RSS514

PERFORMANCE	
Max. feed size:	20" / 500 mm
Capacity:	up to 410 st/h - 375 t/h

HOPPER	
Width:	8'9" / 2,70 m
Length:	12'1" / 3,70
Max. Volume:	9.4 yd ³ / 7,2 m ³

SCREEN SURFACE (both decks)	
Length:	14' / 4,30 m
Width:	5' / 1,52 m
Angle:	15 - 19°
Screen decks:	acc. to customer requirements

FEEDER BELT	
Width:	48" / 1200 mm
Type:	Plain belt
Control:	Variable speed

FINES BELT	
Width:	32" / 800 mm
Discharge height:	~ 12'6" / 3,80 m
Control:	Variable speed

MIDS BELT	
Width:	32" / 800 mm
Discharge height:	~ 11'8" / 3,60 m
Control:	Variable speed

OVERSIZE BELT	
Width:	48" / 1200 mm
Discharge Height:	~ 11'2" / 3,40 m
Control:	Variable speed

COLLECTION BELT	
Width:	48" / 1200 mm
Control:	Constant

TRACKS	
Width:	16" / 400 mm
Speed:	0,6 mph - 1 km/h

APRON FEEDER	
Width:	48" / 1200 mm
Type:	Apron
Control:	Variable speed

DRIVE UNIT	
Tier 3A	CAT 4.4 - 102HP / 75kW
Tier 4 Final	JCB444 EcoMax - 126HP / 93kW
Diesel tank:	103 US gallon / 390L
Hydraulic tank:	118 US gallon / 450L

OPTIONS

- > Top deck: Finger tines, bofor bar punch plate or mesh
- > Radio remote control
- > Apron feeder
- > Stage V - CAT 3.6 - 134JP / 100kW
- > Stage V - JCB444 EcoMax - 126HP / 93kW



DIMENSIONS

RSS514

Working dimensions

Length:	44'6" / 13,60 m
Width:	45'6" / 13,90 m
Height:	14'7" / 4,40 m

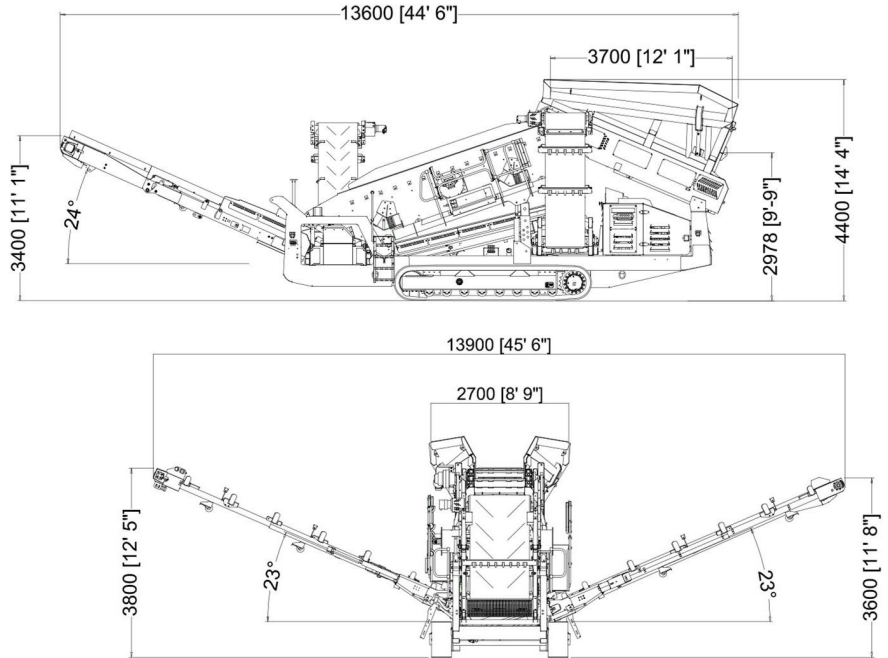

Transport dimensions

Length:	44'7" / 13,60 m
Width:	9'10" / 3,00 m
Height:	11'2" / 3,40 m
Weight Apron feed:	60.630 lbs / 27,5 t
Weight Belt feed:	53.600 lbs / 24,3 t

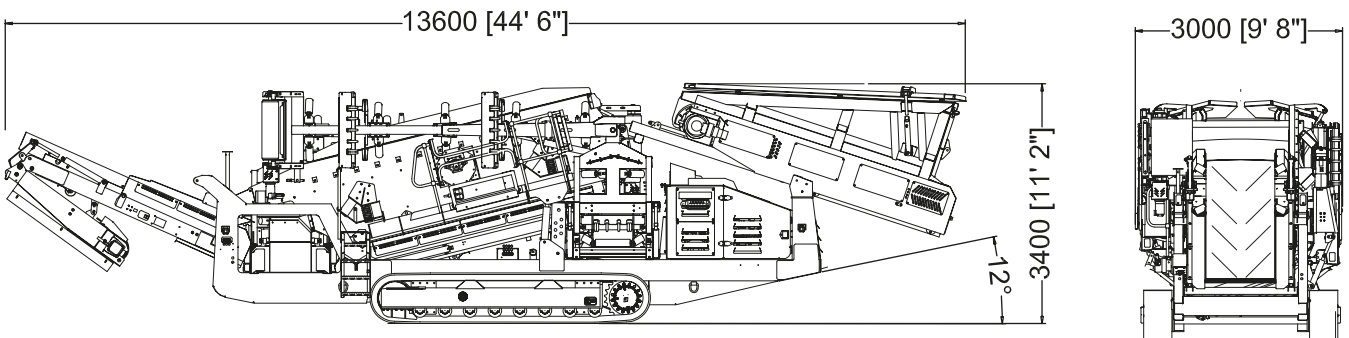

GENERAL INFORMATION



**HIGH & CONSTANT
PERFORMANCE**



**INCREASED
MOBILITY**



**EASE OF
OPERATION**



**MAXIMUM
FLEXIBILITY**



**HYDROSTATIC
DRIVE**



**LONG-TERM
RELIABILITY**



**CLIMATE
FRIENDLY**

Austrian based manufacturer Rockster Austria International GmbH has a longlasting reputation and the know-how in demolition and screening industry.

The product line includes, among others, track mounted impact and jaw crushers, screening machinery and tracked stackers. "Our mobile crushers and screeners are used for profitable & economical recycling and processing of asphalt, concrete and construction waste, as well as for natural stone.

With innovations like The Original DUPLEX system or double-functional return belt, we repeatedly demonstrate our progressive approach towards improving and developing more efficient recycling & processing methods."

Rockster machines are sold in more than 50 countries worldwide. Our sales partner network guarantees the ideal on-site package of product and service in order to support and secure the daily success of our customers.



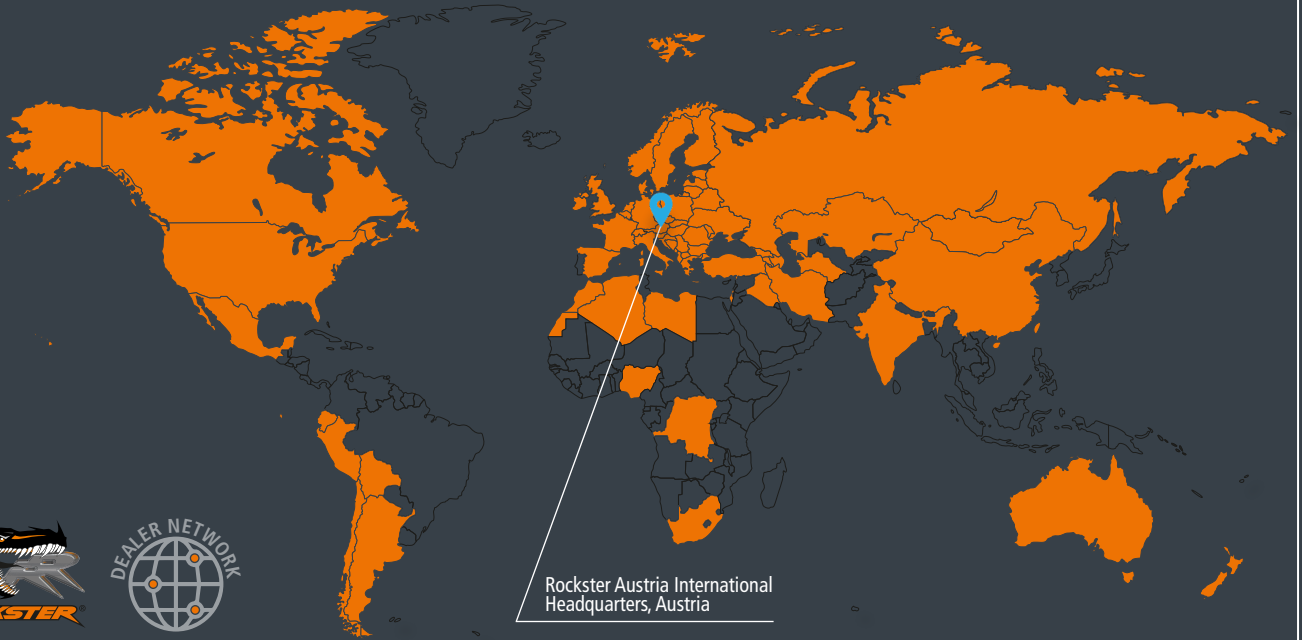

Rockster Austria International
Headquarters, Austria

SOLD IN MORE THAN 50 COUNTRIES WORLDWIDE

**EFFICIENT
SCREENING TECHNOLOGIE**

Rockster Austria International GmbH | Matzelsdorf 72, 4212 Neumarkt i.M., Austria
Tel.: +43 720 70 1212 | office@rockster.at | www.rockster.at

