



RSS712

MOBILE TRACK-MOUNTED SCALPING SCREEN

Feed hopper 6.3 yd³ / 4,8 m³

Screen surface 12'1" x 6'7" / 3,7 x 2,0 m

Transport weight ~ 44,100 lbs / 20,0 t

**EFFICIENT
SCREENING
TECHNOLOGY**



Rockster Austria International GmbH | Matzelsdorf 72, 4212 Neumarkt i.M., Austria
Tel.: +43 720 70 1212 | office@rockster.at | www.rockster.at



ROCKSTER®



HEAVY DUTY SCALPING SCREEN

RSS712

**ROBUST
RELIABLE
FOR TOUGHEST APPLICATIONS**



DESIGNED FOR THE MOST DIFFICULT APPLICATIONS

The RSS712 scalping screen is one of the most robust and reliable scalping screens on the market. Built to handle the toughest of applications, the RSS712 comes with a double deck vibrating screen and the longest stockpiling conveyor available.

FEATURES & BENEFITS

- > Robust chassis & Track
- > Maximum durability
- > Angle adjustable screen box
- > Tipping function activated hydraulically
- > Short set-up time & easy handling
- > Low feeding height
- > Optimal transport dimensions

Technical details

HOPPER	
Width:	1,83 m / 6'1"
Length:	3,15 m / 10'4"
Max. Volume:	4,8 m ³ / 6.3 yd ³
Max. feed size	500 mm / 20" (capacity up to 600 t/h)
MAIN BELT	
Width:	1050 mm / 42"
Type:	Plain belt
Control:	variable speed
Vibrating screen (both decks):	3,70 x 2,00m / 12'2" x 6'9"
Drive unit:	Diesel engine

FEEDER BELT	
Width:	1050 mm / 42"
Type:	Plain belt
Control:	variable speed
DISCHARGE HEIGHT	
Minimum:	2,30 m / 7'6"
Maximum:	3,90 m / 12'8"
POWERPACK	
Tier 3A	T.Deutz - 66HP / 49kW or JCB444 DieselMax - 86HP / 63kW
Tier 4 Final	JCB444 EcoMAX - 74HP / 55kW
Diesel tank:	180L / 39 gallon / 47 US gallon
Hydraulic tank:	375L / 82 gallon / 99 US gallon

Working dimensions

Length:	40'5" / 12,30 m
Width:	8'4" / 2,56 m
Height:	13'3" / 4,05 m

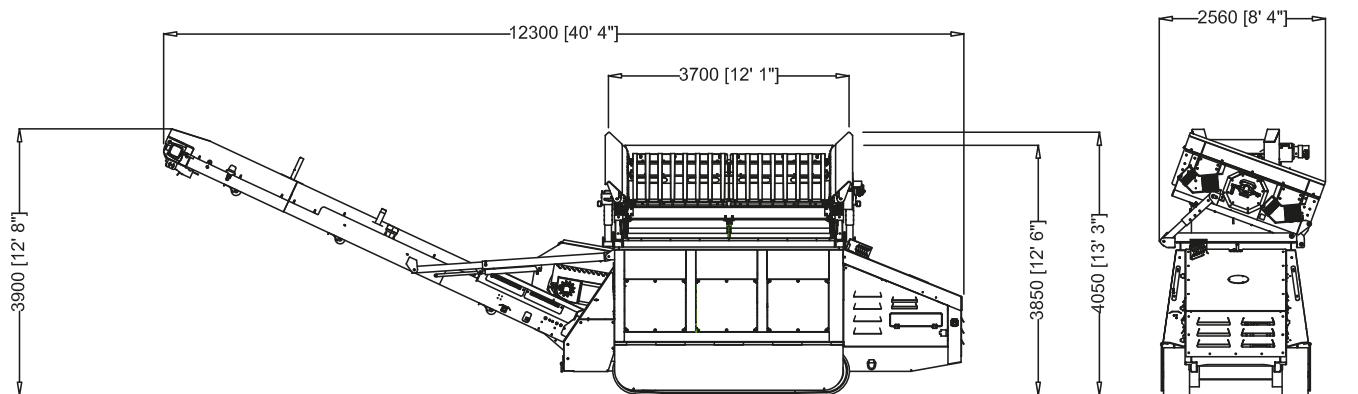

Transport dimensions

Length:	35'6" / 10,80 m
Width:	7'5" / 2,30 m
Height:	10'1" / 3,10 m
Weight:	44,000 lbs / 20,0 t

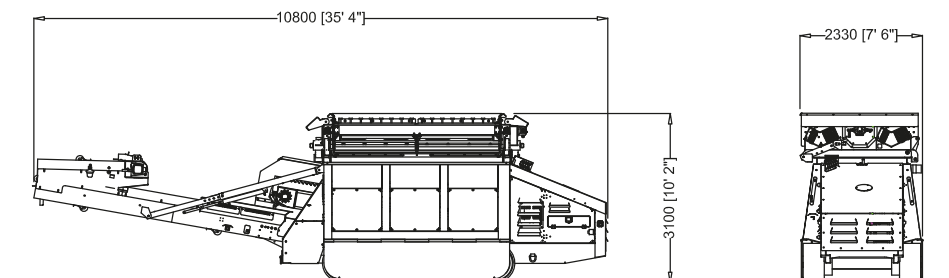

OPTIONS

- > Dust cover for the main belt
- > Radio remote control
- > Overband magnet
- > Screen decks: bofor bars, finger tines, punch plate or mech
- > Stage V engine - T.Deutz 2.9 L4 - 67HP / 50kW

GENERAL INFORMATION



HIGH & CONSTANT PERFORMANCE	INCREASED MOBILITY	EASE OF OPERATION	MAXIMUM FLEXIBILITY	HYDROSTATIC DRIVE	LONG-TERM RELIABILITY	CLIMATE FRIENDLY

Austrian based manufacturer Rockster Austria International GmbH has a longlasting reputation and the know-how in demolition and screening industry.

The product line includes, among others, track mounted impact and jaw crushers, screening machinery and tracked stackers. "Our mobile crushers and screeners are used for profitable & economical recycling and processing of asphalt, concrete and construction waste, as well as for natural stone.

With innovations like The Original DUPLEX system or double-functional return belt, we repeatedly demonstrate our progressive approach towards improving and developing more efficient recycling & processing methods."

Rockster machines are sold in more than 50 countries worldwide. Our sales partner network guarantees the ideal on-site package of product and service in order to support and secure the daily success of our customers.



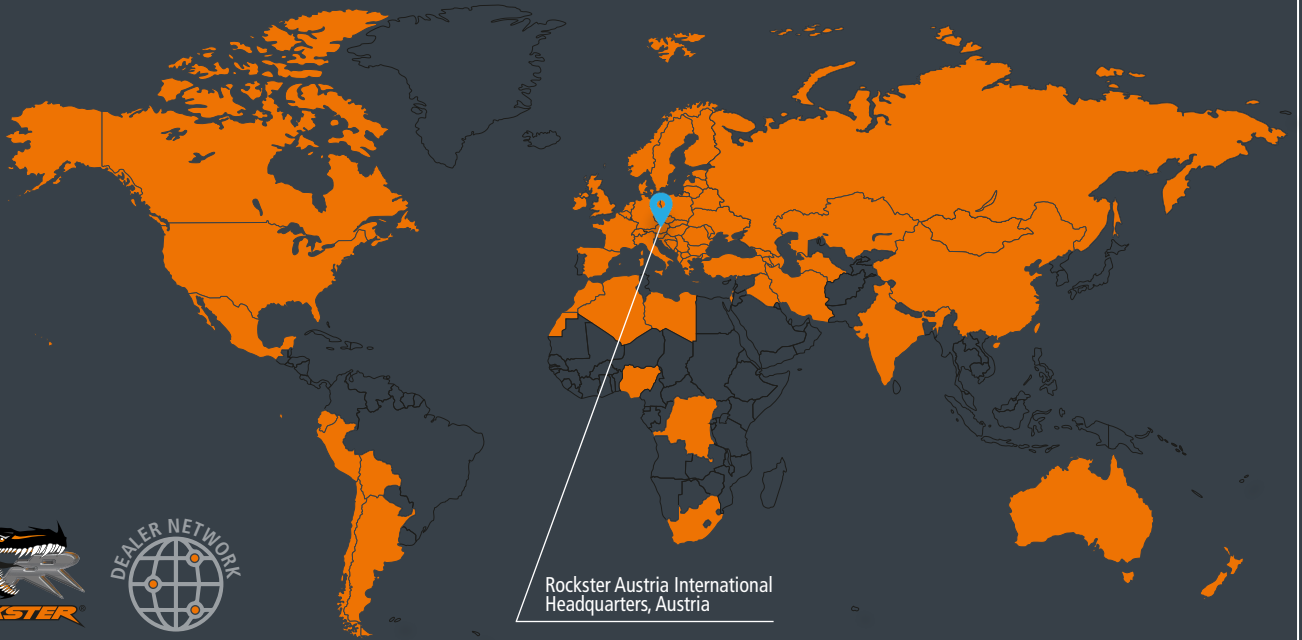

Rockster Austria International
Headquarters, Austria

SOLD IN MORE THAN 50 COUNTRIES WORLDWIDE

**EFFICIENT
SCREENING TECHNOLOGIE**

Rockster Austria International GmbH | Matzelsdorf 72, 4212 Neumarkt i.M., Austria
Tel.: +43 720 70 1212 | office@rockster.at | www.rockster.at

